



Ship To: Name _____

Company _____

Street _____

City _____

State _____ Zip Code _____

Day Time Phone _____

Fax _____

Email _____

Reference: _____

Your job name or PO #

100% STAINLESS STEEL CHASE COVERS

PLEASE CALL FOR PRICING (standard price includes: 2" collar, 3" side drop and cross breaks)

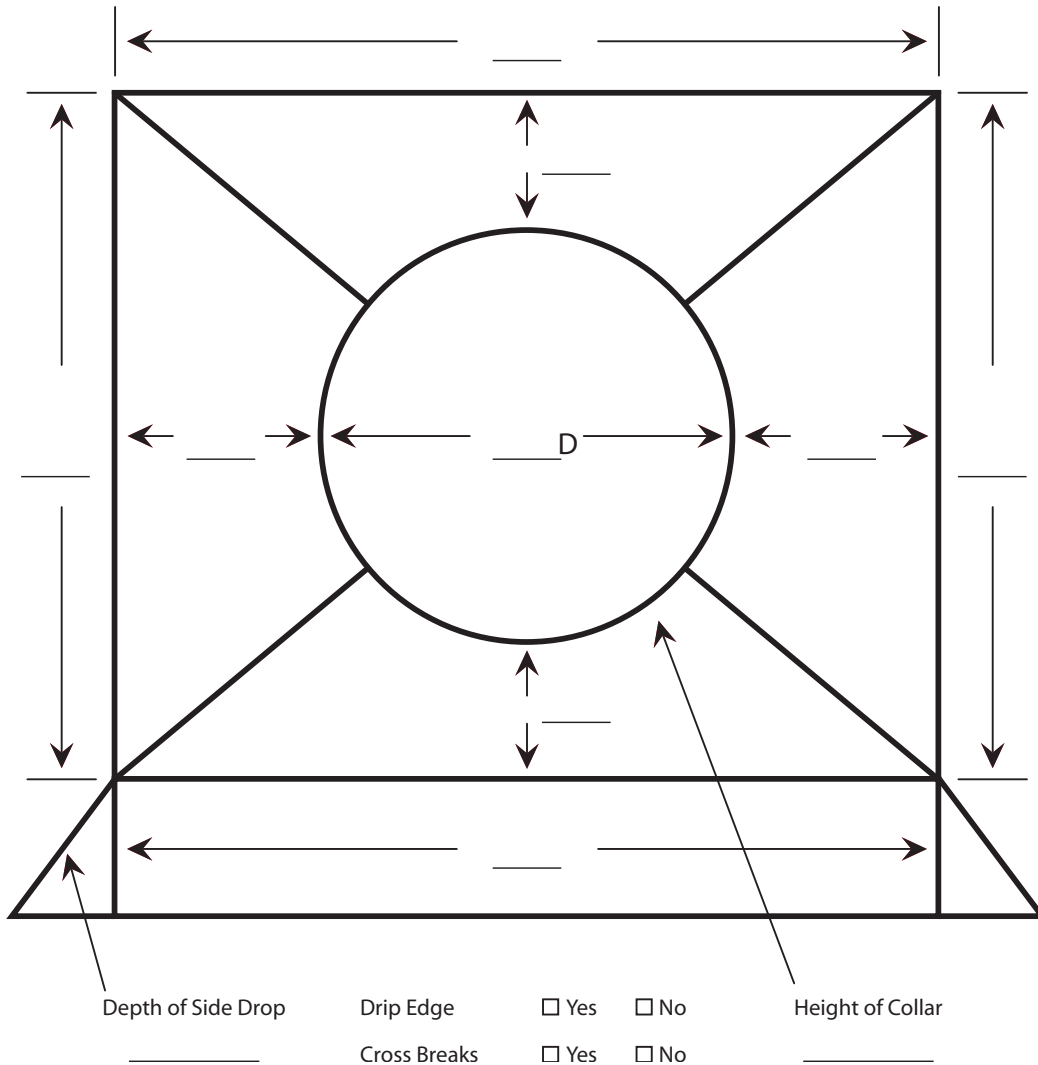

PURCHASER'S SIGNATURE _____ DATE _____

COPY THIS PAGE AND FAX TO 301-740-3489

PLEASE PRINT VERY CLEARLY. CUSTOM CHASE COVERS ARE NOT RETURNABLE