



AIRJET[®]

2100° ALL-FUEL CHIMNEY

Sizes: 6" and 8" Diameters

The high temperature chimney system designed for safety, engineered for efficiency.

- improved technology tested and listed to UL103HT requirements for extra margin of safety
- triple-wall, air insulated for safe, efficient operation
- designed to meet new criteria for wood-burning applications
- exclusive snap-lock design for fast, easy installation
- heavy-duty interior liner

Tools You Will Need:

Power Saber Saw
Hammer and Nails

Screwdriver
Plumb Bob

Caulking Gun
Tin Snips

SUPPLIES: 10d nails, 8d nails, 6d nails, silicone caulk or roof tar, #10 screws, plumbers tape

Please read Instruction Notes inside before starting

Continental Industries, Inc.
Toll Free: 800.735.5272 • Fax: 574-262-2075
www.continentalindustries.com

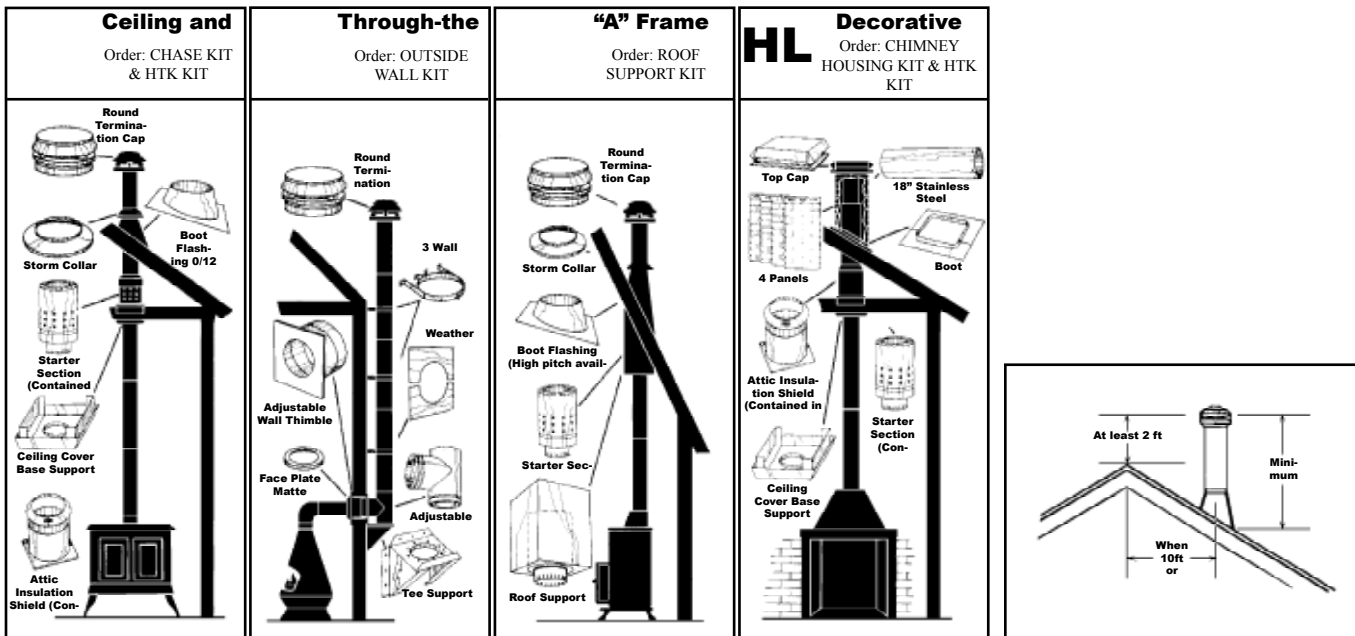

READ ALL OF THESE INSTRUCTIONS CAREFULLY AND FOLLOW THEM EXACTLY !

These instructions are for model 6S and 8S chimneys used for 1,000° F for continuous burn and up to 1,400° F for periods up to one hour and 2,100° F for periods up to 10 minutes.

This chimney is suitable for use with appliances burning gas, oil, coal (**NOTE:** Certain types of coal have a high sulfur content, which causes corrosion of stainless steel. Therefore this type of coal is not recommended for use with factory built chimneys.) or wood such as cooking ranges, heating or fireplace stoves, central furnaces, floor furnaces, hot water and steam heating boilers, recessed or unit heaters, water heaters, domestic type incinerators, bakery ovens, and for industrial type low heat appliances (NFPA - Table 9 - IP). (These chimneys shall be installed in accordance with local building codes or as recommended by NFPA No. 211 and 54.) Chimneys installed without the use of the starter section (6SS, 8SS) are listed to UL 103 (1,700° only), and may be connected to residential and building heating appliances which are gas or oil fired **ONLY**, as specified in Note 3 to Table 1-2(a) of NFPA 211.

CONTACT LOCAL BUILDING OR FIRE OFFICIALS ABOUT RESTRICTIONS AND INSTALLATION INSPECTIONS IN YOUR AREA.

The chimneys can be installed in single or multi-story buildings with maximum permissible overall height from support to top of housing of 50’.

A minimum clearance of 2 inches of air space to combustible materials, building insulation, enclosure walls, and roof must be maintained. Do not place any insulation material in clearance spaces around pipe. Clearances at floor joists, and ceilings are established by the installation of the factory furnished base supports and firestop shields and may be less than 2”. The flue gas exits must be a minimum of 3’ above the roof and not less than 2’ above any projection within 10’.

A MAJOR CAUSE OF CHIMNEY RELATED FIRES IS FAILURE TO MAINTAIN REQUIRED CLEARANCE (AIR SPACES) TO COMBUSTIBLE MATERIALS, IT IS OF THE UTMOST IMPORTANCE THAT THIS CHIMNEY BE INSTALLED ONLY IN ACCORDANCE WITH THESE INSTRUCTIONS.

Chimney to be sized in accordance with the appliance manufacturer's instructions.

Single wall chimney connector may be used as the connection between the appliance and the first chimney section whether it be at the ceiling or at the wall. Building codes require an 18" minimum clearance between the single wall connector and all combustible surfaces. This clearance is not required at the ceiling when connecting into the base support (CCB) or at the wall when connecting into a through the wall tee. Both of these are UL tested installations.

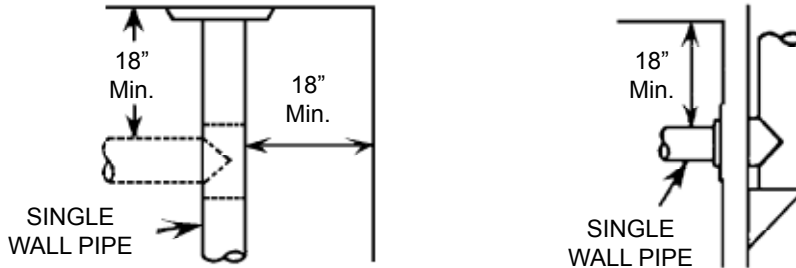

Except for installation in one and two family dwellings, a factory-built chimney that extends through any floor above that on which the connected appliance is located is to be provided with an enclosure having a fire resistance rating equal to or greater than that of the floor or roof assemblies through which it passes.

The following installation applications take into account the various building constructions, single floor, two floor, and multi-floor.

INSTALLATION OF 6S OR 8S CHIMNEY

1. Through the Ceiling Installation

Cut and frame a square opening in the ceiling to receive the base support (6SCCB or 8SCCB), 12 1/2" square for 6S or 14 1/2" square for 8S. See Figure 2 and 2A.

Insert the base support (6SCCB or 8SCCB) from below the opening and raise until the flange contacts the ceiling (or framing). From above drive 8d nails (5 each side) through pre-punched holes inside of support. (see Figure 2)

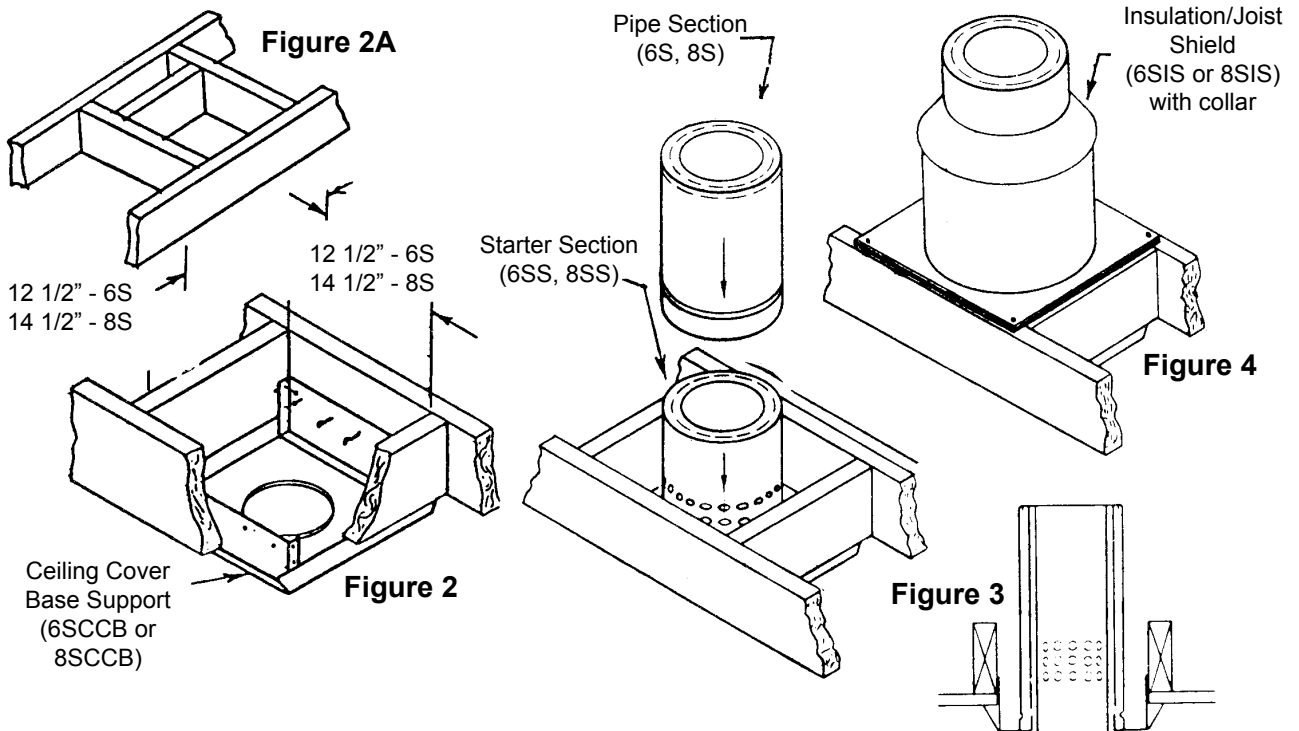

APPLICATION (A) Single Story Installation for 6S and 8S Chimney

(Appliance on Occupancy Floor with Attic Above)

Place the female end of the starter pipe section down over the centering flange on the base support (6SCCB or 8SCCB) (Figure 3). Install first section of pipe into starter section by aligning the seams and pressing straight down until a click is heard. Make sure that the insulation in the attic is removed from around the framed opening, lower the insulation shield (6SIS or 8SIS) down over the pipe until it contacts framing. Nail with 6d nails into the 12 1/2" or 14 1/2" frame using two (2) nails each side as shown in Figure 4. Make sure insulation shield and wood framing contain no opening through which loose insulation material may enter (Figure 5C).

Place insulation shield collar over pipe and push down until it contacts top of the insulation shield. Make sure there is no gap between collar and shield.

Continue installation as required (see Step 2).

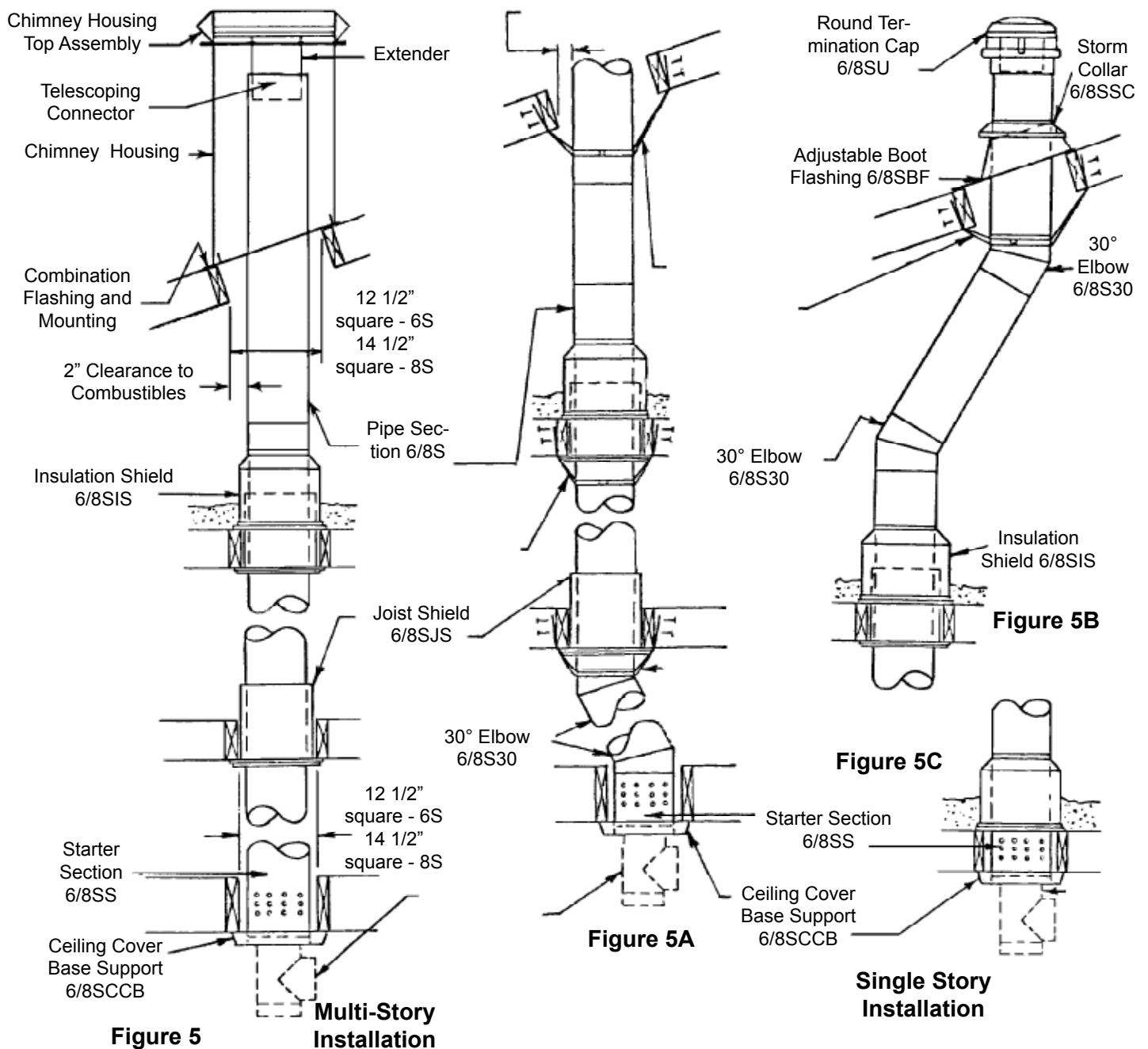

APPLICATION (B) Two or More Story Installation of 6S and 8S Chimney

After the frame opening is completed for the ceiling base support (6SCCB or 8SCCB) and the base support is installed in the first floor level, use a plumb-bob to align and locate the next framed opening in the next floor levels. Frame an opening 12 1/2" square for 6S or for the 8S, 14 1/2" square. See Figure 2A, and 5. Framed openings must line up precisely. **Be sure to maintain the required minimum clearance to**

Install a radiation joist shield (6SJS or 8SJS) from below, at all floors (except roof), above base support with 6d nails (2 each side, 2" from the ends). This provides firestop at the frame opening and establishes and maintains required minimum clearance between chimney section and combustible materials in this area.

The final framed openings (to attic) requires the installation of an insulation shield (6SIS or 8SIS). (Remove insulation from around this area.) Place the female end of the starter pipe section down over the centering flange on the base support (6SCCB or 8SCCB) (see Figure 3).

Then assemble enough pipe sections to pass from base support (6SCCB or 8SCCB) through the joist shield (6SIS or 8SIS). Assemble pipe by aligning seams and pressing straight down until the click is heard. Remove any insulation or other foreign materials from inside joist shield that might have fallen in.

Lower the insulation shield (6SIS or 8SIS) down from above, over the pipe until it sets on the framed opening. Using 6d nails, nail down with 2 nails on each side, 2" from the ends. See Figure 4. Next place insulation shield collar over pipe and push down until it rests on top of insulation shield. Make sure there is no gap between collar and shield. Tighten the stove bolt and nut which draws the collar tight around the pipe.

Continue installation as required (see Step 2).

- STEP 2. Locate the center point where the chimney will pass through the roof by using a plumb-bob. Cut an opening large enough to provide a **minimum of 2" clearance all around the chimney section**. See figure 5 showing frame opening size required.
3. Install the boot flashing (6 or 8SBF) making sure the flashing cone is centered over the roof opening so the chimney pipe is plumb and the **2" air space clearances are maintained**. Before attaching the flashing to the roof, place a bead of caulk under the edges. Slip flashing under overlapping roof shingles as far as possible before nailing flashing to roof. Trim, cut or replace shingles to fit cone as necessary. Thoroughly caulk around edges of flashing. Add chimney sections until the pipe extends through the flashing (see Figure 8.)
 4. Install storm collar (6 or 8 SSC) on the top pipe section and slide down until it contacts the high side of the flashing cone. Put a bead of roofing cement between the storm collar and pipe section to insure a leak free installation.
 5. Chimneys shall extend at least 3 feet above the highest point where they pass through a roof of a building and at least 2 feet higher than any portion of a building within a horizontal distance of 10 feet (see Figure 1). If the chimney extends more than 6', external bracing will be required. Plumbers tape may be wrapped around chimney and secured with a minimum of three (3) guy wires anchored to roof, 120° apart (see Figure 8A).
 6. Install the termination cap (6 or 8SU) tightening the screws on collar until the cap is fastened securely to section.

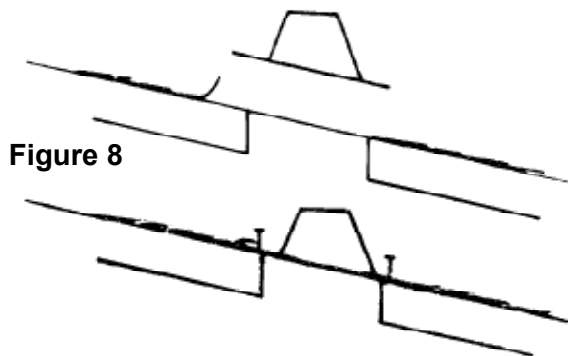

Figure 8

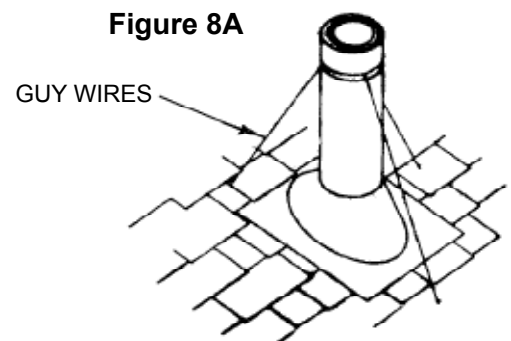

Figure 8A

GUY WIRES

OFFSETS

AirJet 30° elbows (6S30, 8S30) for factory built chimneys may be used where offsets are required. Straight sections of pipe can be used between elbows to increase the amount of the offset. 30° is the maximum allowable angle on offsets. The maximum angled run allowable is **6S - 8 feet, 8S - 8 feet. The 2" clearance to combustibles requirement must be maintained.**

Support the vertical return elbow by using the offset support (6SSB, 8SSB) (see Figure 5A). This offset support is to be attached on or immediately above the vertical return elbow. **NOTE:** If elbow offset is located in lower floors, offset support (6SSB, 8SSB) should be provided at each floor level (see Figure 5A). After positioning the offset support and tightening the stove bolt and nut, attach support straps to the nearest joists or frame by driving nails through the holes provided in the straps. Use two (2) 10d nails or #10 wood screws per support strap. If additional support is desired, use plumbers tape and nail to structural rafters.

Complete installation as described earlier making sure **2" clearance to combustibles requirement is maintained.**

THROUGH THE WALL (6S and 8s Models only)

1. Mark the height on the wall as the center of the opening where the single wall pipe meets the AirJet Chimney. Maintain minimum clearance to combustible materials from single wall connector as established by the local building codes. Most codes require at least 18" clearance from stove pipe to combustible surfaces. Stove pipe is used only within the room from appliance to chimney tee. Never enclose single wall stove pipe.
2. Cut opening through the wall (see Figure 9) which provides required air space clearance in every direction (6S - 12 1/2" square, 8S - 14 1/2" square).
3. Install and center wall thimble into inside opening. Nail with 6d nails through the four (4) corners. Adjust thimble sleeve to proper wall thickness. Maximum wall thickness covered by wall thimble is 8". See Figure 9.
4. Outside the house - place the tee (6ST, 8ST) on the support (6SWS, 8SWS) and line up the tee snout with the wall thimble. Place the support flush against the wall and mark through the screw holes onto the wall (see Figure 10). Remove the tee from the support and screw the support to the wall at the marked location with nine (9) #10 screws. Place the tee, female end down, while sliding the snout through the thimble making sure to maintain required clearance to combustibles. Tee snout must protrude through the wall a minimum of 1". Snout is adjustable for 4 1/2" to 8" thick wall. For wall thickness greater than 8", it will be necessary to install a short (1 foot) chimney section so that the proper clearances can be maintained and the connector installation would not terminate inside the wall cavity.

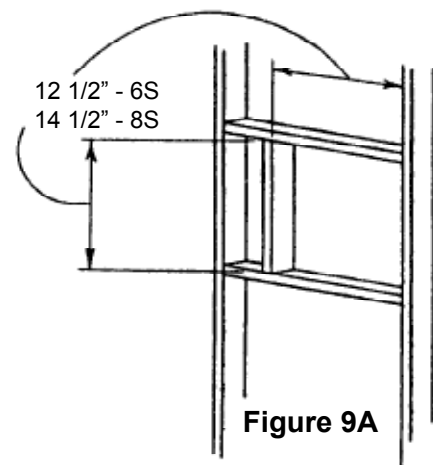
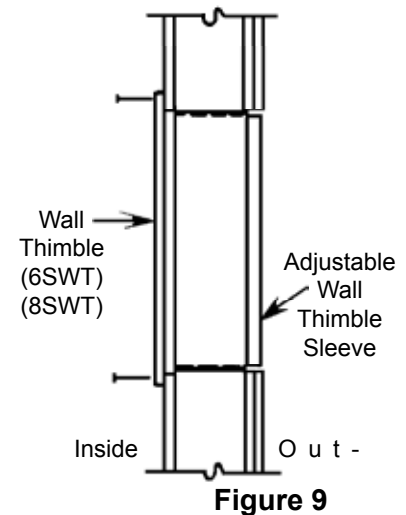

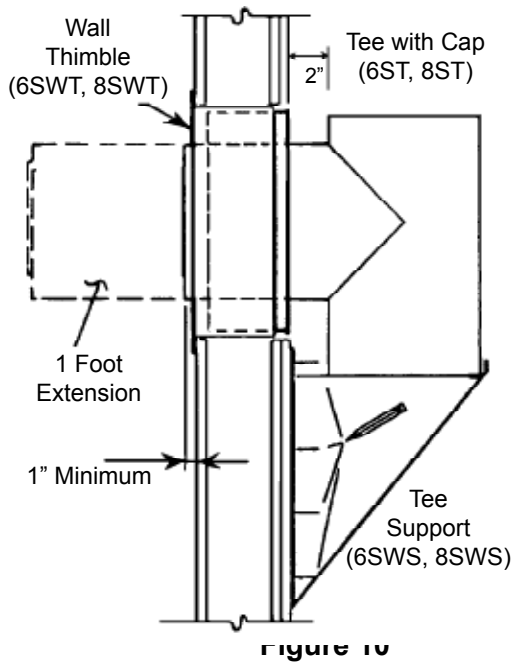

5. Add sections on top of tee, snap locking pipe sections together making sure to align the seams.
6. Secure the pipe to the wall by installing a wallband (6SWB, 8SWB) every 5'. The bands should be attached with #10 screws. The center bracket of the band should be turned so it is parallel to the pipe (see Figure 11). Tighten the screws on the wall bands securely to form a secure anchor against wind and weather.
7. Top of pipe must reach at least 3' above roof. If pipe is 10' or less from the roof peak or building projection, then it must terminate at least 2' above such peak or projection height (see Figure 1).
8. Place termination cap (6SU, 8SU) down until it is firmly in place. Tighten the screws on collar until cap is fastened securely on the top pipe section.

9. Install weather shield (6SWSH, 8SWSH). Using screws provided, place two halves of weather shield around the tee to cover the outside wall opening. Edges of the shield should be well caulked to provide a weather-tight seal.

10. Inside the house, attach the face plate (6SFP, 8SFP) to the tee or chimney section, by placing over the outer ring of the triple wall pipe.

NOTE: In geographical areas experiencing sustained low ambient temperatures, it is recommended that the exterior mounted chimney be enclosed below the roof line. Enclosing the chimney reduces heat loss, reduces condensation, reduces creosote build-up and improves draft. Remember to maintain **2" air space clearance to combustibles and building installation.**

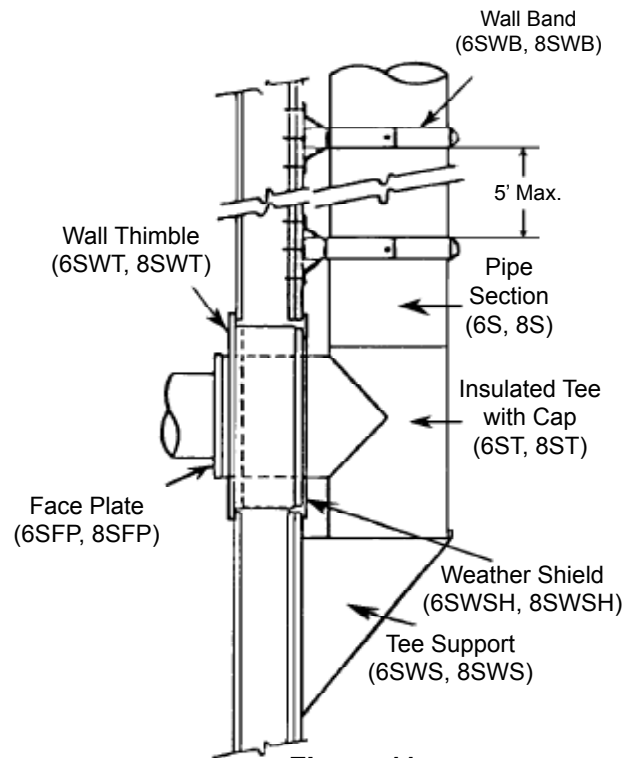

Figure 11

OUTSIDE OVERHANG

NARROW OVERHANG

You can work around a narrow overhang by using two (2) 30° elbows (6S30, 8S30) to offset the chimney. Two elbows will give approximately 4" to 6" offset. If more offset is needed, you will need to add a straight pipe section between the elbows. One wall band should be placed just below the first elbow, a second wall band should be installed around the vertical return elbow. Second wall band will require framing out from wall for attachment. Remember to maintain the **2" clearance to combustible** requirement. Terminate as described in Step 8.

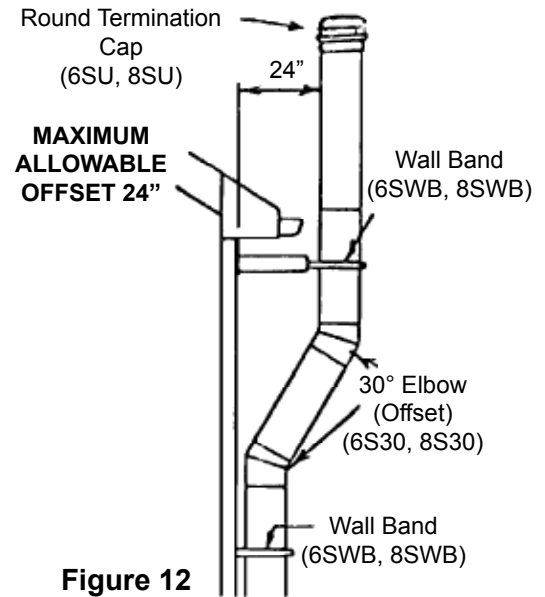

Figure 12

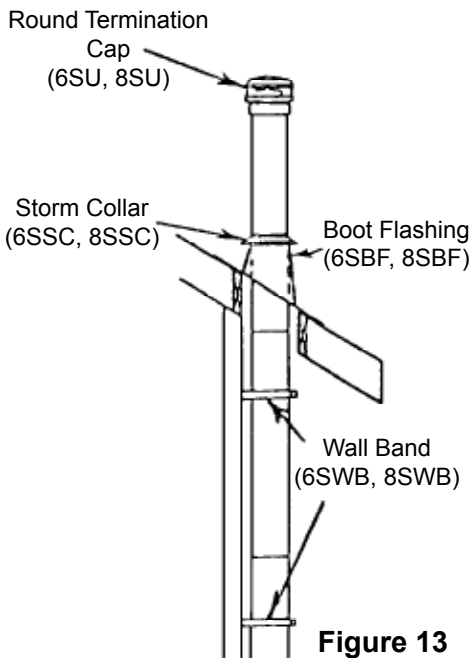

Figure 13

WALL OVERHANG

If the overhang is too wide for offsetting, finish the chimney as you would with a ceiling installation. Remember to maintain the **2" clearance to combustible** requirement. Cut the required opening in the roof, then use boot flashing (6SBF, 8SBF), storm collar (6SSC, 8SSC), and round termination cap (6SU, 8SU) as described in Step 3.

INSTALLATION OF DECORATIVE HOUSING

Follow instructions provided with housing, on carton. For chimney installation utilizing decorative housing, follow instructions printed on housing carton.

“A” OR CATHEDRAL ROOFS

1. Work between two rafters if at all possible. Mark the center of the opening by using a plumb-bob. Cut and frame the opening to the size of the roof support (6HRS, 8HRS) you will use. 6S - 12 1/2" square, 8S - 14 1/2" square.

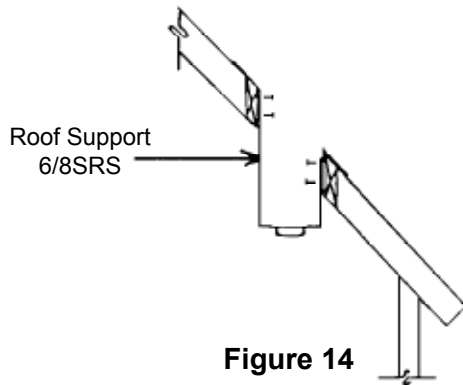

Figure 14

2. Determine the roof pitch and make a template to match. Mark this angle on the roof support (6SRS, 8SRS) and cut to fit using tin snips. Nail through all four (4) sides from above into the framing, using 8d nails, with at least two (2) per side (see Figure 14).

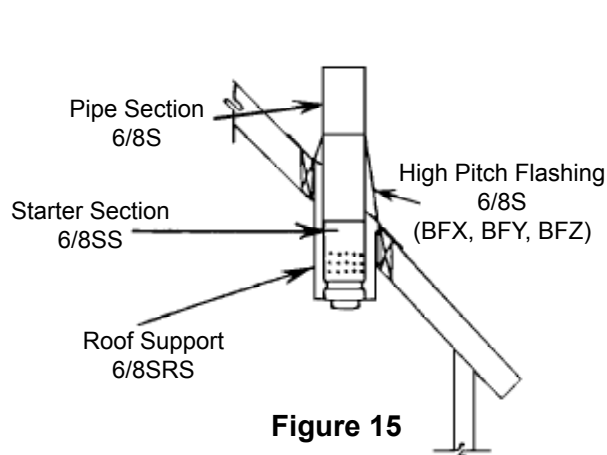
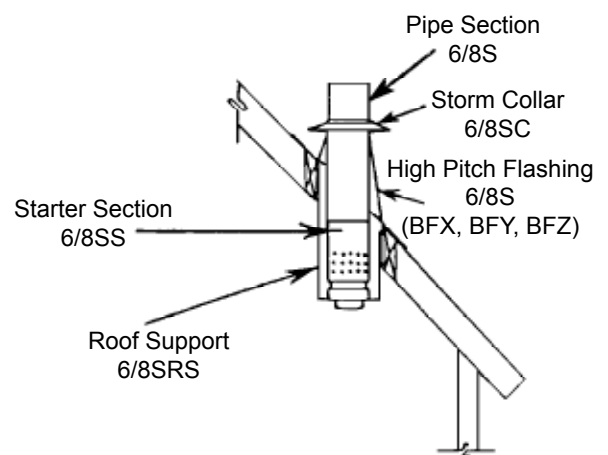

Figure 15



3. Place starter pipe section into roof support (6SRS, 8SRS) with female end down over centering flange. Install section of pipe onto starter section by aligning the seams and pressing straight down until a click is heard. Slide boot flashing (6SBF, 8SBF) over pipe into place over roof opening. Lay bead of caulk under edge of flashing. Check to see that chimney is vertical and attach flashing to roof. Add caulk around edges.

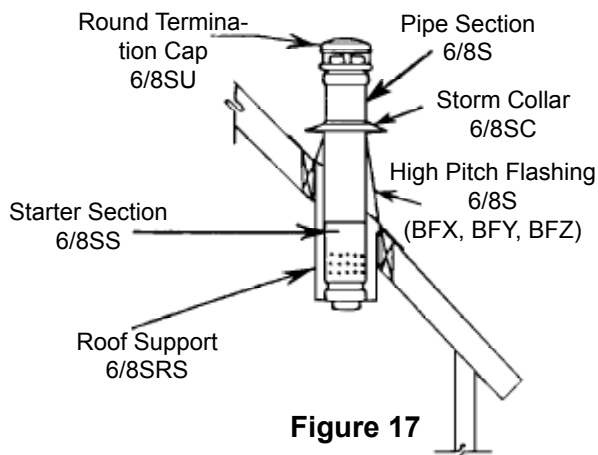

Figure 17

4. Install storm collar (6SSC, 8SSC) and cap (6SU, 8SU) to complete installation as described in Step 8.

CREOSOTE AND SOOT - FORMATION AND NEED FOR REMOVAL

When wood is burned slowly, tar and other organic vapors are produced. These vapors combine with expelled moisture from the burning wood to form creosote vapors. These creosote vapors condense in a relatively cool chimney flue (below 250°). As a result, creosote residue accumulates and coats the lining of the pipe. Creosote is highly combustible in its solid or semi-liquid state and burns at an extremely high temperature. When the creosote ignites, a chimney fire results. The high temperatures of these fires could damage the chimney or even cause a house fire. Read and follow closely the operating and maintenance instructions from the appliance manufacture.

Even if the creosote does not catch fire, problems will result if the chimney is not checked and cleaned properly on a regular basis. The creosote will continue to build up until it restricts the existing air flow (draft) causing appliance heat production to decrease to a minimum.

The chimney should be inspected at least once every month during heating season to determine the extent of creosote or soot build-up.

If creosote or soot has accumulated it should be removed by the following steps to reduce the risk of chimney stoppage or fire.

CHIMNEY CLEANING PROCEDURES

First be sure fires and coals in the appliance are dead and the chimney pipe is cool. If possible, remove all ashes from appliance.

1. Loosen termination cap collar screws, and gently pull cap upward to remove. (On decorative housing, unscrew four (4) screws and remove top cap assembly.) Carefully clean cap to top assembly with a wire bench brush and/or a rough burlap or canvas cloth, or a chimney cleaning brush.
2. Disconnect the smoke (single wall) pipe from appliance. Be careful not to scatter the soot and fly ash that will be inside. Remove each section of smoke pipe and take outdoors. Clean each section in the same manner as the top was cleaned.
3. Place a plastic bag around the bottom section of chimney pipe. Seal the plastic bag around the opening with tape so no debris will escape.
4. Assemble chimney cleaning brush and necessary rods (available at most hardware stores) as described by the manufacture.
5. Insert the cleaning assembly (brush first) into open chimney flue and push or lower it progressively, working it up and down with a twisting motion against the sides of the chimney flue. Continue to do this until you have worked your way to the bottom.
6. The plastic bag may need to be emptied several times before the cleaning operation is completed.
7. Reassemble the smoke pipe and remount the termination cap or top assembly.
8. Inspect all chimney joints to be certain they are properly secured.

THROUGH THE WALL CHIMNEY CLEANING

1. Follow instructions as outlined except as noted below for tee.
2. Remove the clean-out cap from under the tee support. Place a plastic bag under the support so it will collect and hold debris. Seal the plastic bag around the opening with tape so no debris will escape. Clean tee snout in the same manner as the top cap and smoke pipe sections were cleaned. Shove debris toward tee support (outside) so it will be collected in the plastic bag. Then attach a plastic bag around the tee snout in the same manner as on the tee support.

NOTE: If deposits are very heavy or you are unable to clean the chimney yourself, call a professional contractor.